

STAFF REPORT

TO: Hailey Planning and Zoning Commission
FROM: Mariel Platt, Planner 
RE: Subdivision Ordinance Amendment – Exhibit A, City Standards, Parking Standards Drawing Number 808
HEARING: November 2, 2009

Note: Staff analysis is in lighter type.

Notice

Notice for the public hearing on November 9, 2009 was published in the Idaho Mountain Express and mailed to public agencies and area media on October 14, 2009.

Proposal

Amendments to Exhibit A of the Subdivision Ordinance are proposed by the City. These amendments would establish that the Parking Standard Drawing Number 808 would apply to “on-street” parking only. Please see the attached page for the actual proposed language.

Procedural History

The existing drawing number 808 applied to both on-site and on-street parking; it did not differentiate between different parking locations. With the recent adoption of on-site parking standards by the City Council, it is necessary to amend the drawing to specify that drawing number 808 pertains to on-street parking only.

Department Comments

No comments were received.

Standards of Evaluation

Section 13.3.1 of the Subdivision Ordinance sets forth the standard of evaluation for text amendments:

- 1. The Commission shall consider the relationship of the proposed amendment to the Comprehensive Plan in making its recommendation to the Council.**

The Commission should consider how the proposed amendments relate to the various policies and implementation items of the Comprehensive Plan, particularly the following:

5.8 Due Process and Public Input

Goal: To develop clear land use and development procedures that protect the public welfare for all development.

- 2. If the proposal initiated by an applicant is not in accordance with the Comprehensive Plan, the Commission shall notify the applicant of this finding and inform the applicant that they must apply for an amendment to the Comprehensive Plan before the Ordinance can be amended.**

The proposed amendments are city initiated and appear to meet the Comprehensive Plan. If the Commission determined that it does not meet the Comprehensive Plan, the City shall amend the Comprehensive Plan before Ordinance can be amended.

Summary

The Commission shall hold a public hearing and determine whether the proposed amendments are in accordance with the Comprehensive Plan. The Commission shall recommend, with reasons therefore, to the Council that the proposed amendment be granted or denied, or that a modified amendment is granted.

Motion Language

Approval:

Motion to recommend the City Council approve the proposed amendments to the City Standards, Exhibit A, Parking Standard Drawings Number 808, finding that the amendments are in accordance with the Comprehensive Plan.

Denial:

Motion to deny the proposed amendments to the City Standards, Exhibit A, Parking Standard Drawings Number 808, finding that _____ [the Commission should cite which standards are not met and provided the reason why each identified standard is not met].

Continuation:

Motion to continue the public hearing upon the proposed amendments to the City Standards, Exhibit A, Parking Standard Drawings Number 808 to _____ [the Commission should specify a date].

PARKING TABLES

A	B	C	D	E	F	G
0°	10'0"	10.0	12.0	25.0	32.0	-
20°	10'0"	16.6	11.0	29.2	44.2	34.8
30°	10'0"	19.2	11.0	20.0	49.4	40.7
45°	10'0"	21.9	13.0	14.1	56.8	49.7
60°	10'0"	23.2	18.0	11.5	64.4	57.3
70°	10'0"	23.1	18.0	10.6	64.2	60.8
80°	10'0"	22.4	24.0	10.2	68.8	67.1
90°	10'0"	21.0	24.0	10.0	66.0	66.0

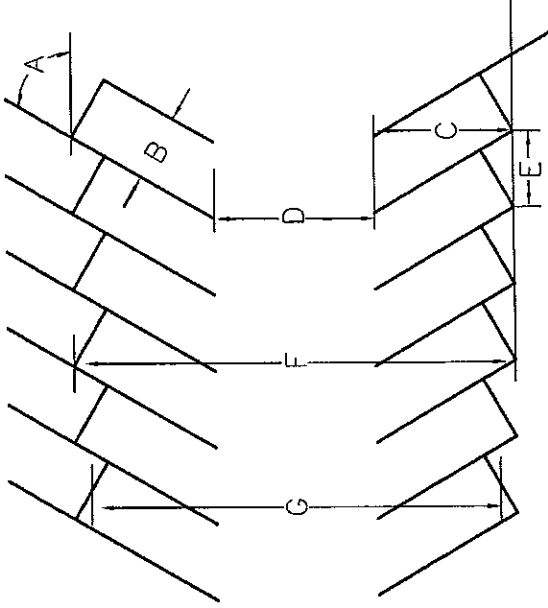

PARKING PLAN LAYOUT

N.T.S.

- A. PARKING ANGLE
- B. STALL WIDTH
- C. STALL TO CURB
- D. AISLE WIDTH
- E. CURB LENGTH PER CAR
- F. CURB TO CURB
- G. STALL CENTER

NOTES

1. Angle parking on city streets shall be 60°
2. Dimensions D, F and G are for parking lots only

REVISIONS

2002 CITY OF HAILEY
IMPROVEMENT STANDARD
DRAWINGS

ON STREET
PARKING STANDARDS

808

DWG. NO.

HAILEY ORDINANCE NO. _____

AN ORDINANCE OF THE CITY OF HAILEY, IDAHO, AMENDING HAILEY'S SUBDIVISION ORDINANCE, ORDINANCE NO. 821, BY AMENDING ARTICLE 5, EXHIBIT A, TO DELETE DRAWING NUMBER 808 AND REPLACE AND TO REPLACE IT WITH A NEW DRAWING NUMBER 808; PROVIDING FOR A SEVERABILITY CLAUSE; PROVIDING FOR A REPEALER CLAUSE; AND PROVIDING FOR THE EFFECTIVE DATE.

WHEREAS, the proposed amendments are generally in accordance with the Comprehensive Plan;

WHEREAS, the proposed amendments will not create excessive additional requirements at public cost for public facilities and services; and

WHEREAS, the proposed amendments will be in accordance with the welfare of the general public.

NOW, THEREFORE, BE IT ORDAINED BY THE MAYOR AND CITY COUNCIL OF THE CITY OF HAILEY, IDAHO, AS FOLLOWS:

Section 1. Exhibit A of the Hailey Subdivision Ordinance No. 821, is hereby amended by the deletion of Drawing No. 808 and the replacement of a new Drawing No. 808, titled "On Street Parking Standards" attached hereto.

Section 2. Should any section or provision of this Ordinance be declared by the courts to be unconstitutional or invalid, such decision shall not affect the validity of the Ordinance as a whole or any part thereof other than the part so declared to be unconstitutional or invalid.

Section 3. All City of Hailey ordinances or resolutions or parts thereof, which are in conflict herewith, are hereby repealed.

Section 4. This ordinance shall be in full force and effect from and after the required three (3) readings, approval, and publication according to law.

PASSED AND ADOPTED BY THE HAILEY CITY COUNCIL AND APPROVED BY THE MAYOR THIS ____ DAY OF _____, 2009.

Rick Davis, Mayor, City of Hailey

Attest:

Mary Cone, City Clerk